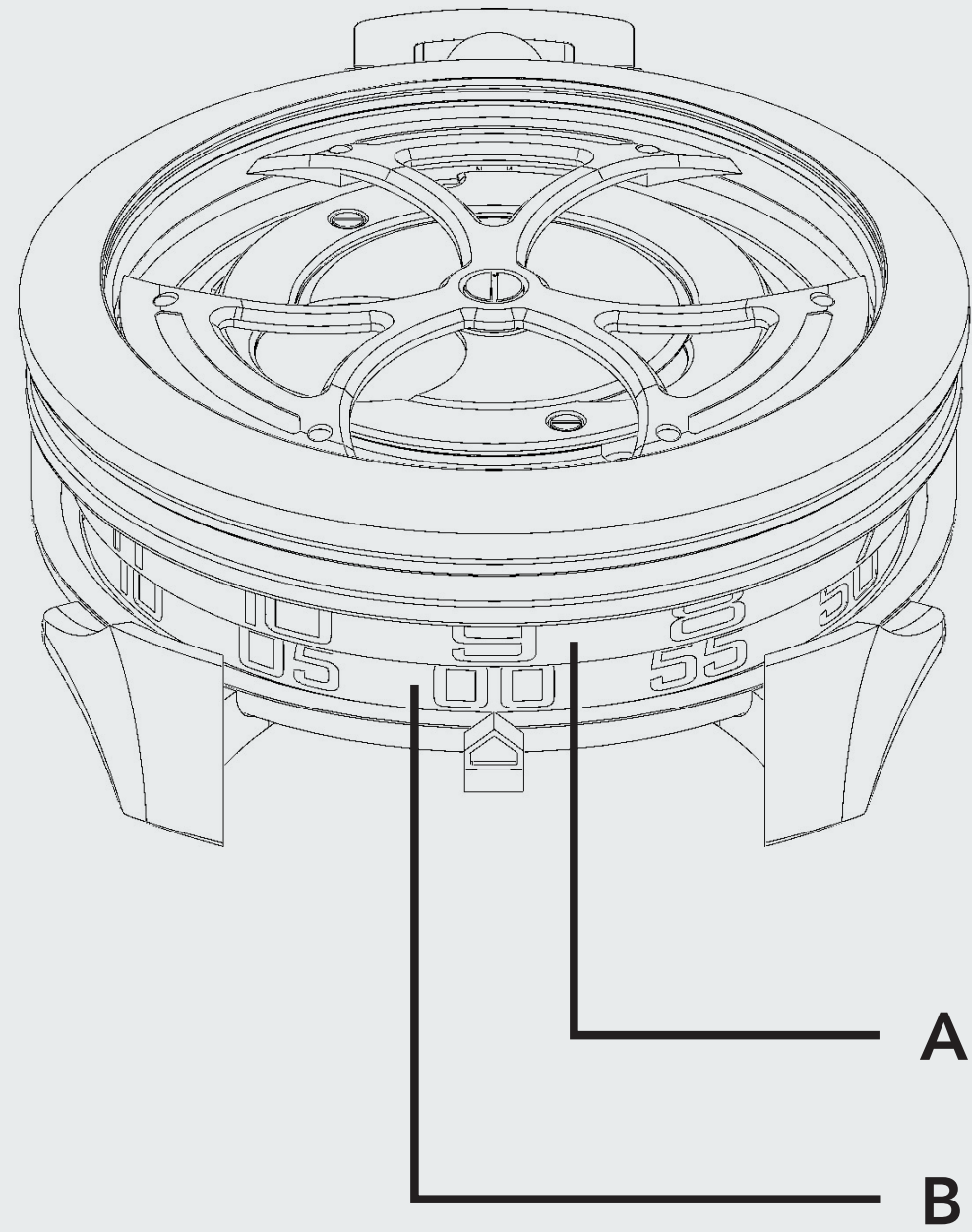

**1****2****3**

# M.A.D'1

## **1** FUNCTIONS

A → Hours

B → Minutes

## **2** WINDING

Your watch is equipped with an automatic movement.

If it has stopped, wind the movement by turning the crown several times clockwise.

## **3** TIME-SETTING

Pull crown "out" and rotate to set the time.

The time can be set forwards or backwards by rotating clockwise or anti-clockwise.

Push the crown back against the case when finished.